

| MODEL NO.  | OVERALL FRAME WIDTH (A) | CLEAR DOOR OPENING (B)             | BREAKOUT OPENING (C)   | ACTIVE & SIDELITE LEAF WIDTH (D) | ROUGH OPENING WIDTH (E) |
|------------|-------------------------|------------------------------------|------------------------|----------------------------------|-------------------------|
| VMT3FBO-8  | 96"<br>[2438.4]         | 53 3/4"<br>[1365.3]                | 82 1/2"<br>[2095.5]    | 32 1/2"<br>[825.5]               | 96 1/2"<br>[2451.1]     |
| VMT3FBO-10 | 120"<br>[3048.0]        | 69 3/4"<br>[1771.7]                | 106 1/2"<br>[2705.1]   | 40 1/2"<br>[1028.7]              | 120 1/2"<br>[3060.7]    |
| VMT3FBO-12 | 144"<br>[3657.6]        | 85 3/4"<br>[2178.1]                | 130 1/2"<br>[3314.7]   | 48 1/2"<br>[1231.9]              | 144 1/2"<br>[3670.3]    |
| KEY:       |                         | (2*A/3)-10 1/4"<br>(2*A/3)-[260.4] | A-13 1/2"<br>A-[342.9] | (A/3)+ 1/2"<br>(A/3)+[12.7]      | A+1/2"<br>A+[12.7]      |

CONSULT FACTORY FOR ALL CUSTOM CONFIGURATION SIZES OR SIZES OVER 12'.

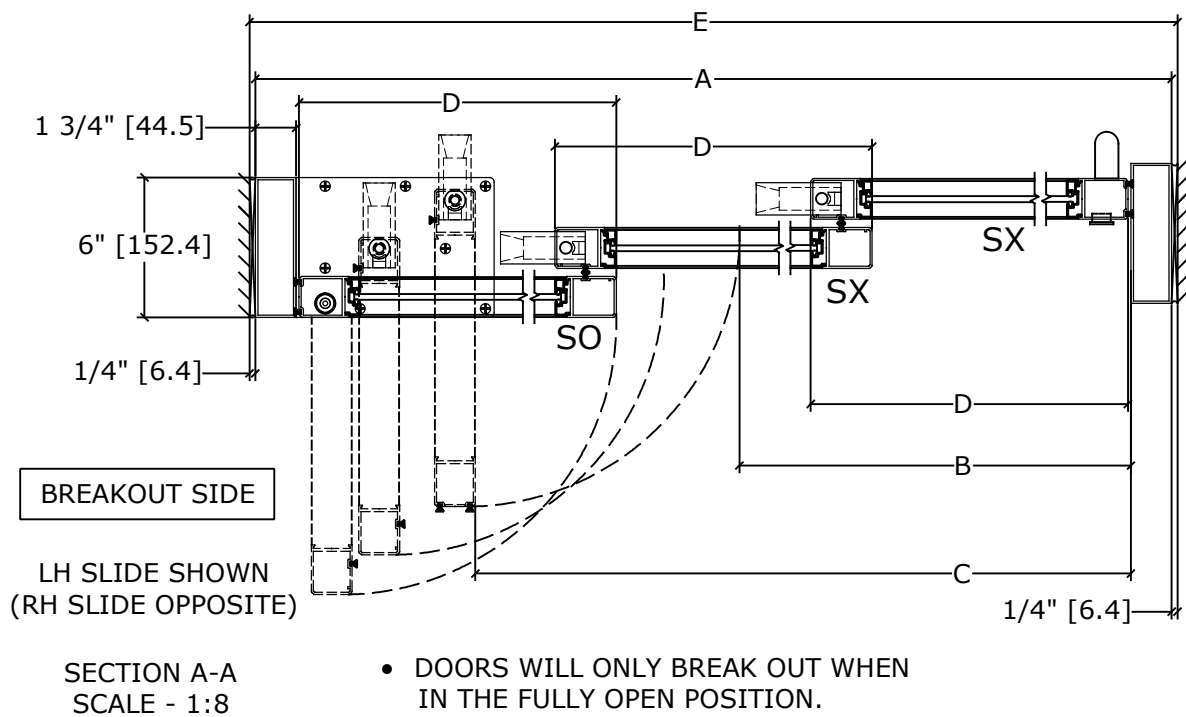

#### NOTES:

##### STANDARD PACKAGE CONSISTS OF:

- STANDARD FINISH:  
CLASS 1, .018MM, CLEAR- AA-M12C22A41
- NARROW STILE RAILS
- 1/4" GLASS STOPS AND BLOCKS
- PULL HANDLE(S) AND RECESSED FINGER PULL(S)
- NURSE ASSIST MAGNETIC CATCHES
- FULL OPENING DAMPENING DEVICE

##### OPTIONS AVAILABLE:

- SPECIAL FINISHES
- PACKAGE WILL ACCEPT UP TO 1 1/4" [31.8] INSULATED GLASS, SEE SHEET AA-13 FOR DETAILS
- 7" & 10" BOTTOM RAILS, SEE SHEET AA-14 FOR DETAILS
- MUNTINS, SEE SHEET AA-14 FOR DETAILS
- SEE SHEET OS-1 FOR ALL OTHER OPTIONS.

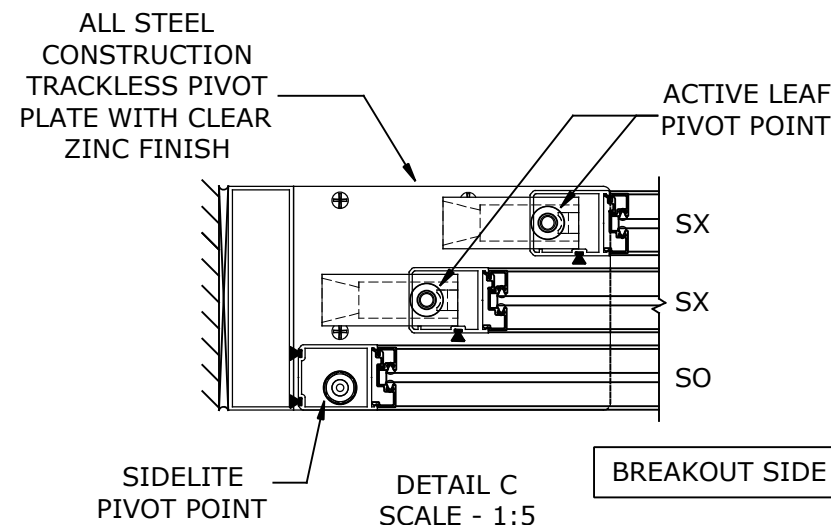

REFER TO RELEVANT [LOCAL, STATE, NATIONAL, OR AHJ] BUILDING CODE FOR MIN DOOR HEIGHT & MIN/MAX WIDTH ALLOWABLE FOR EGRESS REQUIREMENT IN CONJUNCTION WITH TABLE.

|         |         |      |          |        |     |      |          |      |     |      |          |
|---------|---------|------|----------|--------|-----|------|----------|------|-----|------|----------|
| DWG NO. | 1016213 |      |          |        |     |      |          |      |     |      |          |
| DRN BY  | DBN     | DATE | 02/22/17 | CHK BY | CLW | DATE | 03/03/17 | REV. | 2.0 | DATE | 05/24/17 |